

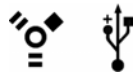

ROCPORT 4 FIREWIRE / USB HARD DRIVE



ROCPORT 4 PORTABLE FIREWIRE & USB HARD DRIVE

The innovative Rocstor drive design provides exceptional quietness, light weight storage, capacity, performance, power management and quality required by today's demanding notebook systems. The Rocport drives redefine state-of-the-art storage for Mac and PC mobile computing. Rocport drives are equipped with both USB and FireWire (IEEE 1394) connections.

Benefits:

- FireWire (IEEE1394) and USB 2.0 (1.1)
- Plug-and-play connectivity with PC and Macintosh Computers
- Share, backup, or transport large files
- Cross Platform Support
- Transfer and exchange information
- Automatic configuration without a need to set up ID's or terminators
- Aluminum enclosure allows excellent dissipation of heat and low noise
- A fast and an easy way to add Extra Digital Storage to your PC or MAC.
- Requires little effort to connect, plug and play.
- FireWire or USB ports.
- Hot-Pluggable makes it possible to connect or disconnect the peripheral without turning off the computer.
- Cables are simple and easy to connect
- Guaranteed compatibility.
- 1 year limited warranty

STORE YOUR FUTURE with unlimited applications for your High-Performance Hard Drive

- Store Massive amount of Audio and Video data such as Digital music, Digital Pictures and Movies
- Store thousands of Digital photos.
- Stores Digital Movies off of your computer
- Store games
- Use as Back up storage for your other drives
- Unlimited storage of data with multiple FireWire / USB external hard drives.
- Secure your Hard Drive by locking it up in a safe place.
- Flexibility will also allow you to transfer files between computers.

Dimensions and weight

5.0 x 2.9 x 0.6 inch(12.7 x 7.5 x 1.5 cm), 6.4 Ounces

Interface

- FireWire/IEEE 1394/iLink & USB 2 (1.1 compatible)

Transfer Rate

- Up to 400 Mbps FireWire
- Up to 480 Mbps USB2.0

Connectors

- 6-pin FireWire, IEEE 1394 connector x 2
- 4-pin USB connector x 1
- Power On/Off switch x 1

Power Requirement

Rocport Drive is powered by the Interface Bus; No External Power Supply Required. Optional Universal AC Power Adapter available.

PACKAGE CONTAINS:

- FireWire / USB external hard drive
- FireWire and USB cable
- Quick Install Manual

SYSTEMS REQUIREMENTS

Macintosh Users:

- Power Mac, iMac G3 and G4, eMac, G4 and G5 Models with Built-in **FireWire** or **USB Ports**
- Minimum 64 MB RAM (128MB recommended)
- Apple System Software 9.1 or Higher

PC Users:

- Pentium II 200Mhz or greater with built-in USB 2.0 or USB1.1 and IEEE 1394 / iLink Interface or FireWire enabled Connection
- Minimum 64 MB RAM (128 MB recommended)
- Windows 98 SE (second edition) or higher, Windows 2000, Me and XP

Hardware and Software installation for Apple Computers.

Note: Hard Drives are shipped pre-formatted with Macintosh (HFS Plus) extended format, for testing propose and should mount automatically on the desktop; if it dose not mount for any reason, follow the instruction according to your Operating System version.

Hardware and Software Installation for Mac OS 9.1 or Higher

- Plug the FireWire or USB cable to the FireWire or USB port on the drive and then plug the other end of the FireWire or USB cable to the FireWire or USB port at the back of the computer
- Turn On the drive; wait for this message window to come up on the screen. “This disk is unreadable by the computer “ and follow below
- Do you want to initialize the disk?
- Name: _____
- Format: Mac OS Extended.
- Name the hard drive and Select Mac Os Extended Under Format Type,
- Click Initialize and Hard Drive Icon Will Appear on the Desktop. Ready to be used.

Hardware and Software Installation for Mac OS X or later

- Plug the FireWire or USB cable to the FireWire or USB port on the Rocport drive and then plug the other end of the FireWire or USB cable to the FireWire or USB port at the back of the computer
- Turn On the drive and wait for a message window to come up on the screen “You have inserted a disk containing No volumes that Mac OS X can read”
- To use the unreadable volumes, Click initialize to continue with the disk inserted click Ignore
- The Initialize Button located at the bottom of the same window. To open disk utility
- Select the hard drive in the Volume Scheme.
- Click Erase in the Disk Utility, Select the format type and click erase to initialize the Hard Drive

- The Hard Drive Icon will Appear on the desktop, Ready to be used

Note:

There are several ways to un-mount your FireWire external hard drive. You can drag the External Hard Drive icon to the Trash, wait until the disk icon disappears from the desktop, then disconnect or turn off the FireWire external hard drive.

Or you may also click on the Hard Drive icon on your desktop and press (Apple/command) “Y” on OS 9.1 to 9.2.2, for OS X use (Apple/Command) “E” to un-mount

HARDWARE AND SOFTWARE INSTALLATION FOR PERSONAL COMPUTERS (IBM, HP, COMPAQ, DELL, and Compatibles.)

Installation for Windows 98

Before opening and connecting the external FireWire/USB drive, please make sure that your system has a FireWire or USB interface and it is configured properly.

1. Connect the FireWire or USB cable to the external Hard Drive to the back of the computer.
2. Wait for the system to initialize the Hard Drive.
3. Click on "start", choose and click on "Run".
4. Type "command" in the Run menu and click ok.
5. You will get a "DOS" screen with the "C" prompt.
6. Type FDisk at the prompt and hit enter.
7. Answer "y" to the question: "do you wish to enable large disk support? "
8. You will get a menu with 5 options. Type 5 and hit enter. (By doing this action, you will be at the "change current fixed disk drive option").
9. Choose the disk #2 by typing 2 and hitting enter or if you have more than one physical drive, type the number of the last drive and hit enter.
10. You will get back to the main menu. Make sure that the current fixed disk drive shows the number 2 (or the right drive number if you had more than one physical drive in the system).
11. Choose to create "DOS" partition by typing "1" and hitting enter.
12. Choose create extended "DOS" partition by typing 2 and enter.

13. You should get another screen that shows the maximum available disk space to create. Leave the numbers as default and hit enter.
14. You should get the verification message "extended dos partition created".
15. Hit the "ESC" (Escape) key to continue.
16. By hitting Escape, you get to the next screen that will ask for the "logical drive size", hit enter to have the maximum size for the new drive.
17. By doing the last step, you created a drive letter for your new drive.
18. Hit "ESC" to get back to the main FDisk menu.
19. You should continue hitting the "ESC" key until you get back to the "C" prompt.
20. Type exit at the "C" prompt to go back to windows.
21. Restart the computer.
22. After the computer restarts, double click on "My Computer" and you will see a new drive letter for the new hard drive.
23. Right click on the drive letter (it could be d: e: or different letter, depending on how many volumes you have in the computer), choose and click "format".
24. At the menu click "Start" to start the formatting.
25. After the format is done, the new hard drive is ready for use.

Installation for windows 2000 / XP operating systems:

Before opening and connecting the external FireWire/USB drive, please make sure that your system has a FireWire or USB interface and it is configured properly.

1. Connect FireWire or USB cable to the external Hard Drive and the computer.
2. Turn the hard drive on.

3. Wait for few seconds for the system to initialize the Hard Drive.
4. Right click on my computer, choose and click on "Manage".
5. Choose and double click on "Storage".
6. Choose and double click on "Disk Management". You will notice that the disk is displayed as an "unknown drive"; (the words in the drive menu displays "Not Initialized")
7. (If the initialize Wizard comes on follow the menus and finish initializing and skip to step 11)
8. Right click on the "unknown drive" icon and choose and click the "Initialize Disk" option.
9. Click O.K. on next menu.
10. The disk status will change to "On Line".
11. Under the capacity gage of the hard drive you will have the word "Unallocated"
12. Right click on the word "Unallocated" on the new disk and choose new partition. By clicking on new partition you will get the "new partition wizard".
13. Click on next and choose "Extended", and then again choose next, Click Finish
14. You will get a "Free Space" message instead of "Unallocated" on the drive status.
15. Right click on the "Free Space" words and choose and click "New Logical drive".
16. You will get the "New Partition Wizard"
17. Click Next.
18. Click next again to choose the maximum capacity for the hard drive.
19. Click next again.
20. Click on "Perform a Quick Format" and click next. (Make sure that the Quick Format is check marked.)
21. Click Finish and wait for the system to show "Healthy" on the hard drive status bar.

22. Exit from the hard drive management by clicking the "X" on the right upper side of the window.
23. Your hard drive is ready to be used.

CAUTION: Do not unplug your Rocport external hard drive while Active or in a process of Transferring, Storing, files as this could result in data loss and disk damage.

CAUTION: Do not DROP or JOLT your Rocport External Hard Drive or attempt to open the drive and service it yourself. These actions will void the warranty.

TECHNICAL SUPPORT SERVICES

For Technical Support on your new Rocport external hard drive for 100 days of free technical support, you must register your product with Rocstorage, Inc. To register please visit us at www.rocstor.com and click on the Registration link. When calling for support, please have the serial number and system hardware information available.

ROCPORT

USB and FIREWIRE Cable Installation Guide

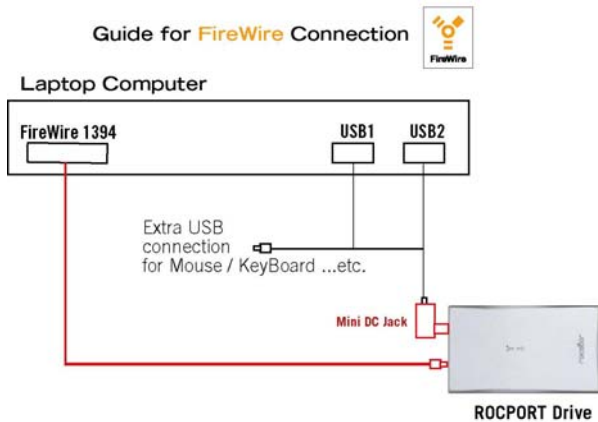
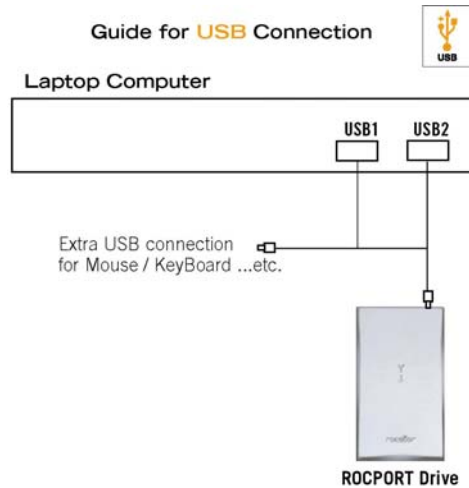

ROCSTOR PRODUCTS WARRANTY AND TECHNICAL SUPPORT INFORMATION

General Terms

EXCEPT AS EXPRESSLY SET FORTH IN THIS LIMITED WARRANTY, ROCSTOR MAKES NO OTHER WARRANTIES OR CONDITIONS, EXPRESS OR IMPLIED, INCLUDING ANY IMPLIED WARRANTIES OF MERCHANTABILITY AND FITNESS FOR A PARTICULAR PURPOSE. ROCSTOR EXPRESSLY DISCLAIMS ALL WARRANTIES AND CONDITIONS NOT STATED IN THIS LIMITED WARRANTY. ANY IMPLIED WARRANTIES THAT MAY BE IMPOSED BY LAW ARE LIMITED IN DURATION TO THE LIMITED WARRANTY PERIOD. SOME STATES OR COUNTRIES DO NOT ALLOW A LIMITATION ON HOW LONG AN IMPLIED WARRANTY LASTS OR THE EXCLUSION OR LIMITATION OF INCIDENTAL OR CONSEQUENTIAL DAMAGES FOR CONSUMER PRODUCTS. IN SUCH STATES OR COUNTRIES, SOME EXCLUSIONS OR LIMITATIONS OF THIS LIMITED WARRANTY MAY NOT APPLY TO YOU.

This Limited Warranty applies to the Rocstor branded hardware products sold by or leased from Rocstor Storage, Inc., its worldwide subsidiaries, affiliates, authorized resellers, or country distributors (collectively referred to in this Limited Warranty as "Rocstor") with this Limited Warranty. This Limited Warranty is applicable in all countries and may be enforced in any country where Rocstor or its authorized service providers offer warranty service subject to the terms and conditions set forth in this Limited Warranty. However, warranty service availability and response times may vary from country to country and may also be subject to registration requirements in the country of purchase.

Rocstor warrants that the Rocstor hardware product and all the internal components of the product that you have purchased or leased from Rocstor are free from defects in materials or workmanship under normal use during the Limited Warranty Period. The Limited Warranty Period starts on the date of purchase or lease from Rocstor. Your dated sales or delivery receipt, showing the date of purchase or lease of the product, is your proof of the purchase or lease date. You may be required to provide proof of purchase or lease as a condition of receiving warranty service. You are entitled to warranty service according to the terms and conditions of this document if a repair to your Rocstor branded hardware is required within the Limited Warranty Period. This Limited Warranty extends only to the original purchaser or lessee of this Rocstor branded product and is not transferable to anyone who obtains ownership of the Rocstor branded product from the original purchaser or lessee.

Rocstor products are manufactured using new materials or new and used materials equivalent to new in performance and reliability. Spare parts may be new or equivalent to new. Spare parts are warranted to be free from defects in material or workmanship for thirty (30) days or for the remainder of the Limited Warranty Period of the Rocstor hardware product in which they are installed, whichever is longer.

During the Limited Warranty Period, Rocstor will repair or replace the defective component parts or the hardware product. All component parts or hardware products removed under this Limited Warranty become the property of Rocstor. The replacement part or product takes on either the Limited Warranty status of the removed part or product or the thirty (30) day limited warranty of the spare part. In the unlikely event that your Rocstor product has a recurring failure, Rocstor, at its discretion, may elect to provide you with a replacement unit of Rocstor's choosing that is at least equivalent to your Rocstor branded product in hardware performance. Rocstor reserves the right to elect, at its sole discretion, to give you a refund of your purchase price or lease payments (less interest) instead of a replacement. This is your exclusive remedy for defective products.

YOU SHOULD MAKE PERIODIC BACKUP COPIES OF THE DATA STORED ON YOUR HARD DRIVE OR OTHER STORAGE DEVICES AS A PRECAUTION AGAINST POSSIBLE FAILURES, ALTERATION, OR LOSS OF THE DATA. BEFORE RETURNING ANY UNIT FOR SERVICE, BE SURE TO BACK UP DATA AND REMOVE ANY CONFIDENTIAL, PROPRIETARY, OR PERSONAL INFORMATION. ROCSTOR IS NOT RESPONSIBLE FOR DAMAGE TO OR LOSS OF ANY PROGRAMS, DATA, OR REMOVABLE STORAGE MEDIA. ROCSTOR IS NOT RESPONSIBLE FOR THE RESTORATION OR REINSTALLATION OF ANY PROGRAMS OR DATA OTHER THAN SOFTWARE INSTALLED BY ROCSTOR WHEN THE PRODUCT IS MANUFACTURED.

Rocstor does not warrant that the operation of this product will be uninterrupted or error-free. Rocstor is not responsible for damage that occurs as a result of your failure to follow the instructions that came with the Rocstor branded product.

This Limited Warranty does not apply to expendable parts. This Limited Warranty does not extend to any product from which the serial number has been removed or that has been damaged or rendered defective (a) as a result of accident, misuse, abuse, or other external causes; (b) by operation outside the usage parameters stated in the user documentation that shipped with the product; (c) by the use of parts not manufactured or sold by Rocstor; or (d) by modification or service by anyone other than (i) Rocstor, (ii) a Rocstor authorized service provider, or (iii) your own installation of end-user replaceable Rocstor or

Rocstor approved parts if available for your product in the servicing country.

These terms and conditions constitute the complete and exclusive warranty agreement between you and Rocstor regarding the Rocstor branded product you have purchased or leased. These terms and conditions supersede any prior agreements or representations-including representations made in Rocstor sales literature or advice given to you by Rocstor or an agent or employee of Rocstor-that may have been made in connection with your purchase or lease of the Rocstor branded product. No change to the conditions of this Limited Warranty is valid unless it is made in writing and signed by an authorized representative of Rocstor.

Limitation of Liability

IF YOUR ROCSTOR BRANDED HARDWARE PRODUCT FAILS TO WORK AS WARRANTED ABOVE, YOUR SOLE AND EXCLUSIVE REMEDY SHALL BE REPAIR OR REPLACEMENT. ROCSTOR'S MAXIMUM LIABILITY UNDER THIS LIMITED WARRANTY IS EXPRESSLY LIMITED TO THE LESSER OF THE PRICE YOU HAVE PAID FOR THE PRODUCT OR THE COST OF REPAIR OR REPLACEMENT OF ANY HARDWARE COMPONENTS THAT MALFUNCTION IN CONDITIONS OF NORMAL USE.

ROCSTOR IS NOT LIABLE FOR ANY DAMAGES CAUSED BY THE PRODUCT OR THE FAILURE OF THE PRODUCT TO PERFORM, INCLUDING ANY LOST PROFITS OR SAVINGS OR SPECIAL, INCIDENTAL, OR CONSEQUENTIAL DAMAGES. ROCSTOR IS NOT LIABLE FOR ANY CLAIM MADE BY A THIRD PARTY OR MADE BY YOU FOR A THIRD PARTY.

THIS LIMITATION OF LIABILITY APPLIES WHETHER DAMAGES ARE SOUGHT, OR A CLAIM MADE, UNDER THIS LIMITED WARRANTY OR AS A TORT CLAIM (INCLUDING NEGLIGENCE AND STRICT PRODUCT LIABILITY), A CONTRACT CLAIM, OR ANY OTHER CLAIM. THIS LIMITATION OF LIABILITY CANNOT BE WAIVED OR AMENDED BY ANY PERSON. THIS LIMITATION OF LIABILITY WILL BE EFFECTIVE EVEN IF YOU HAVE ADVISED ROCSTOR OR AN AUTHORIZED REPRESENTATIVE OF ROCSTOR OF THE POSSIBILITY OF ANY SUCH DAMAGES.

THIS LIMITED WARRANTY GIVES YOU SPECIFIC LEGAL RIGHTS. YOU MAY ALSO HAVE OTHER RIGHTS THAT MAY VARY FROM STATE TO STATE OR FROM COUNTRY TO COUNTRY. YOU ARE ADVISED TO CONSULT APPLICABLE STATE OR COUNTRY LAWS FOR A FULL DETERMINATION OF YOUR RIGHTS.

Options and Software

The Limited Warranty terms and conditions for Rocstor options are as indicated in the Limited Warranty applicable to Rocstor options. ROCSTOR DOES NOT WARRANT SOFTWARE PRODUCTS, INCLUDING ANY SOFTWARE PRODUCTS OR THE OPERATING SYSTEM PREINSTALLED BY ROCSTOR. Rocstor's only obligations with respect to software distributed by Rocstor under the Rocstor brand name are set forth in the applicable end-user license or program license agreement. Non-Rocstor hardware and software products are provided "AS IS." However, non-Rocstor manufacturers, suppliers, or publishers may provide their own warranties directly to you.

Software Technical Support

Software technical support is defined as assistance with questions and issues about the software that was either preinstalled by Rocstor on the Rocstor branded product or that was included with the Rocstor branded product at the time of your purchase or lease of the product. Technical support for software is available for the first ninety (30) days from date of product purchase or lease. Your dated sales or delivery receipt, showing the date of purchase or lease of the product, is your proof of the purchase or lease date. You may be required to provide proof of purchase or lease as a condition of receiving software technical support. After the first ninety (30) days, technical support for software that was either preinstalled by Rocstor on the Rocstor branded product or included with the Rocstor branded product at the time of your purchase or lease of the product is available for a fee.

Warranty Period

Warranty Period for Rocport FireWire/USB Hard Drives are 1 Year Parts and Labor.

Types of Warranty Service

Your Rocstor Limited Warranty consists of repair or replacement of defective parts, including hard drives identified by Rocstor Support Organization as "pre-failure."

Carry-in Warranty Service Available Monday - Friday

Under the terms of carry-in service, you may be required to deliver your Rocstor product to Rocstor Service Center or an authorized service location for warranty repair. You must prepay any shipping charges, taxes, or duties associated with transportation of the product. In addition, you are

responsible for insuring any product shipped or returned. You assume risk of loss during shipping.

Rocstor Replaceable Parts Program

Where available, the Rocstor Replaceable Parts program ships approved replacement parts directly to you to fulfill your warranty. This will save considerable repair time. After you call the Rocstor Technical Support Center at 1.818.449.2000, a replaceable part can be sent directly to you. Once the part arrives, call the Rocstor Technical Support Center. A technician will assist you over the phone to ensure that the installation is quick and easy.

Service Upgrades

Rocstor offers extra coverage for your product. For information on service upgrades, refer to www.rocstor.com.

Service upgrades purchased in one country are NOT transferable to another country.

Contacting Rocstor

- In the United States, refer to the Rocstor website at www.rocstor.com.

- **1.818.449.2000**
Toll-free technical support in the United States and Canada,
5 days a week, 9:00 a.m. to 6:00 p.m. Pacific Standard Time

Be sure to have the following information available before you call Rocstor:

- Product serial number, model name, and model number
- Applicable error messages
- Add-on options
- Operating system
- Third-party hardware or software

1103B-v2

Rocstor is a trademark and Rocport is a trademark of Rocstorage, Inc. All other names are trademarks of their respective companies.

Mac is a trademark of Apple Computer, Inc., registered in the U.S. and other countries. Mac and Mac logo are trademarks of Apple Computers, Inc. registered in the U.S. and other countries.